

TO OPEN

Release the locking hook **A** on the side of the stroller and push the front axles forwards. (Fig. 1)
Press down the bottom lock **B** carefully with your foot until you can hear it engage. (Fig. 2)

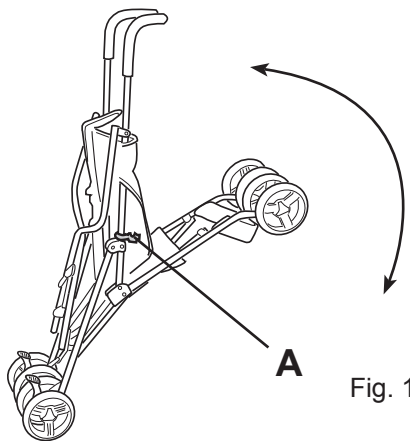

Fig. 1

TO FOLD

Push the locking lever behind the bottom lock **B** with your foot forwards and upwards. (Fig. 2)

Release the secondary lock by pushing lever **C** down with your foot. (Fig. 2)

Fold the buggy by pushing both handgrips forwards. Fasten the locking hook **A**. (Fig. 1)

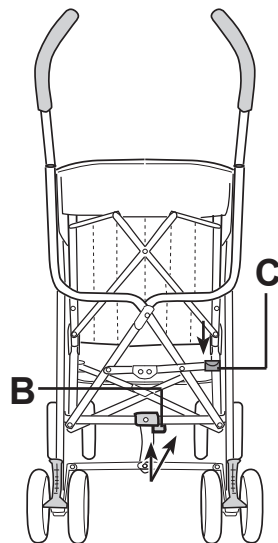

Fig. 2

TO FIT THE FRONT WHEELS

Push the double wheel block **D** onto the upper front wheel housing **E** until it engages. (Fig. 3)

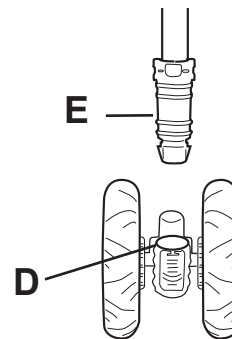

Fig. 3

TO FIX AND TO RELEASE THE BRAKES

TO FIX:

Press the brake levers **F** downwards with your foot. Make sure the brakes have engaged. (Fig. 4)

TO RELEASE:

Push the brake levers **F** upwards. (Fig. 4).

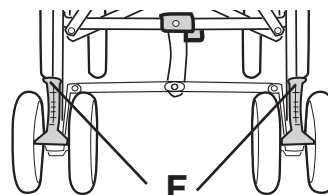

Fig. 4

!	SAFETY	!
<p>Before putting your child in the stroller engage the brakes to make sure it doesn't roll away. Never leave the stroller without engaging the brakes.</p>		

TO FIX AND TO SWIVEL THE FRONT WHEELS

TO FIX : Turn the front double wheels so that the fixing lever **H** faces the front. Push the lever **H** on the double wheel block upwards until it engages. (Fig. 5)

TO SWIVEL: Press the lever **H** on the double wheel block downwards. (Fig. 5)

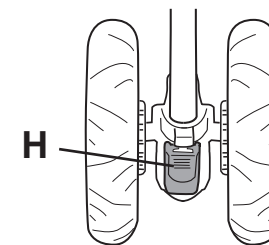

Fig. 5

TO FIT THE CANOPY

Push the canopy fitting hooks **I** onto the handlebar tubes as shown in Fig.6 and fasten the velcros **J** round the tubes. Press the canopy hinge **K** down on both sides. (Fig. 6)

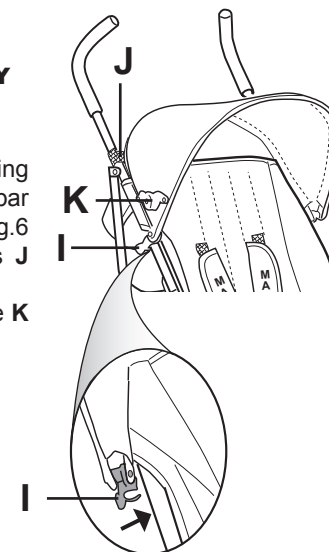

Fig. 6

TO ADJUST THE BACKREST

The backrest can be adjusted to two positions.
(Fig. 7)

SITTING POSITION:
Put the backrest in an upright position and let the fixation hooks **L** on both sides engage. Please take care that the textiles don't get caught.

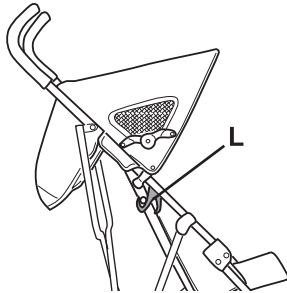

Fig. 7

2. POSITION:
Open the fixation hooks **L** and let down the backrest.

SAFETY BELT

This stroller has a 5-point harness system.
For extra safety **D** rings are provided for the attachment of a separate safety harness. (Fig. 8.3)

TO OPEN: Press the clips **M** and pull them out of the buckle **N**. (Fig. 8.1, 8.2)

TO CLOSE: Push the clips **M** on the right and left shoulder harness into the buckle **N**. (Fig. 8.2)

TO ADJUST: Move the slide adjusters **O** upwards or downwards. (Fig. 8.3)

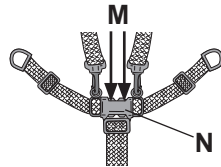

Fig. 8.1

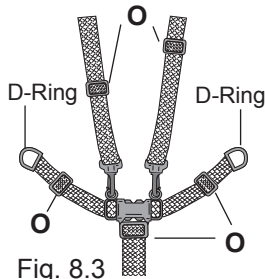

Fig. 8.3

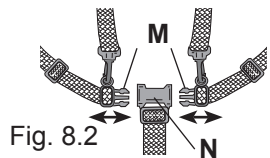

Fig. 8.2

MAINTENANCE

The seat cover is removable and handwashable at 30° C.
The frame should be wiped with a damp cloth and mild soap. Don't use strong detergents, they could damage the plastic parts.
Regularly lubricate the moving parts with silicon oil or silicon spray.

NOTE

This vehicle is intended for children of at least 6 months, and up to a maximum weight of 15kg.
The net basket should not be loaded with more than 3 kg.
The vehicle is designed to be used by one child only. Spare parts or accessories which are not approved by the manufacturer or dealer may not be used.
Periodically check all parts for wear or damage.
Do not use stroller if any component is broken or damaged.
Please do not make any changes to the stroller that could affect the safety.

WARNINGS

- ▲ This seat is not suitable for children under 6 months.
- ▲ It may be dangerous to leave your child unattended.
- ▲ Ensure that all the locking devices are engaged before use.
- ▲ Any load attached to the handle affects the stability of the pram/pushchair.
- ▲ Always use the safety harness.
- ▲ This product is NOT suitable for jogging or inline skating.

USER'S INSTRUCTIONS

MARCO Candy

We congratulate you on your purchase of this stroller.
This pushchair offers optimal performance and value and is very easy to use.

Serial number
(on the back of the washing label):
For all inquiries please indicate the serial number.

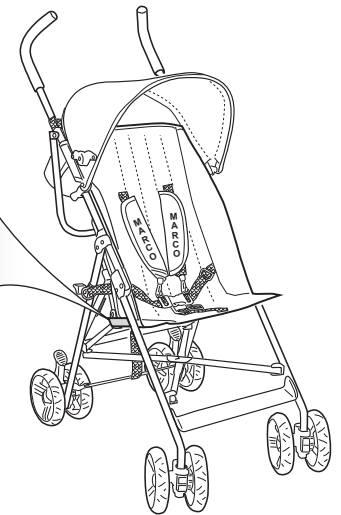

tested according to
EN 1888: 2003 + A1,A2,A3: 2005

IMPORTANT: Read these instructions carefully before use and keep them for future reference. Your child's safety may be affected if you do not follow these instructions.

MARKETING AND DISTRIBUTION
MARCO HANDELSGESELLSCHAFT M.B.H.
A-5440 GOLLING, AUSTRIA
www.marco4bb.com

© MARCO HANDELSGESELLSCHAFT M.B.H., 2008
A-5440-Golling, Austria