

We congratulate you on the purchase of your twin-jogger. The MARCO MARATHON TWIN offers optimal performance + value and is very easy to use. Please read this instructions carefully before using.

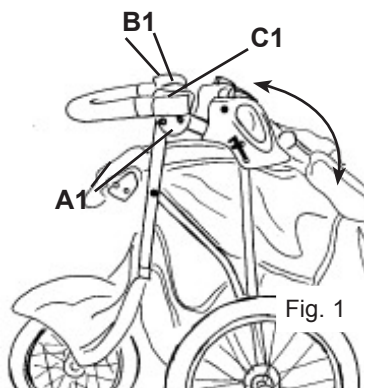

**TO OPEN AND CLOSE**

**TO OPEN:** release the hook A1 and pull up the jogger by the handlebar until the frame locks B1 engage (Fig. 1)

**TO CLOSE:** Press the two frame locks B1, and the safety button C1 on the side of the jogger, fold and fasten the hook A1 (Fig. 1)

**AXLE AND FRONT WHEEL**

**TO FIT:** Before fitting the front wheel, make sure that the lever A3 (Fig. 3) for adjusting the brake block width, is loosened. Now push the axle with wheel into the axle fitting, guiding the security washer A2 into place. Tighten the two nuts B2 (Fig. 2) to secure the axle.

**TO TAKE OFF** the wheel, carry out the above in reverse.

**TO ADJUST THE FRONT WHEEL BRAKES**

After fitting the front wheel, tighten the lever A3. Make sure that the distance right and left between the brake blocks and the wheel rim is equal.

The tension of the brake cables B3 can be regulated by turning the ridged screw C3. This could, for instance, be necessary if the brake blocks D3 become worn after long use (fig. 3). If you want to completely re-tighten the brake cable, screw E3 must be loosened and after the cable tension has been adjusted, must be re-tightened. (fig 3)

**REAR WHEELS AND AXLES**

**ASSEMBLY:** Push the wheel and axle into the fitting until the axle locking lever A4 engages. (Fig. 4)

**TO REMOVE** the wheels pull up the axle locking lever A4 and remove the wheel and axle. (Fig. 4)

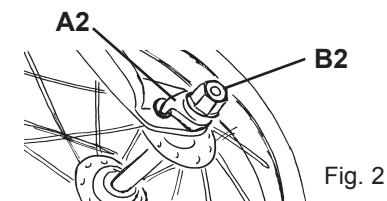

Fig. 2

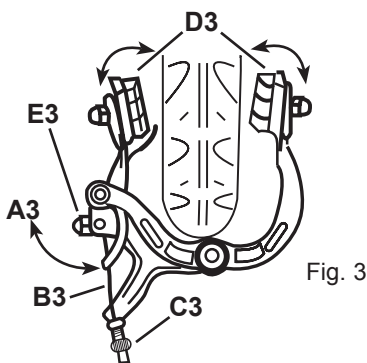

Fig. 3

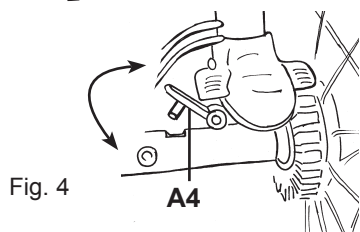

Fig. 4

**TO FIX AND RELEASE THE REAR WHEEL BRAKES**

**TO BRAKE,** press the brake lever A5 downwards with your foot until you can feel the brakes engage. (Fig. 5)

**TO RELEASE,** press the brake lever A5 upwards. (Fig. 5)

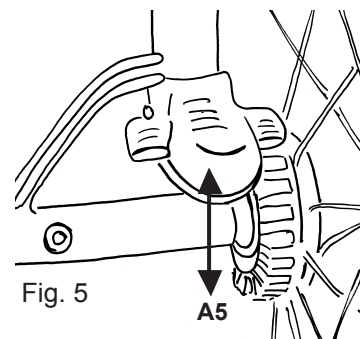

Fig. 5

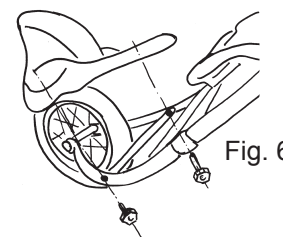

Fig. 6

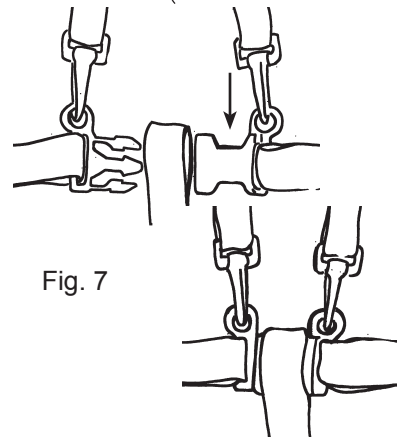

Fig. 7

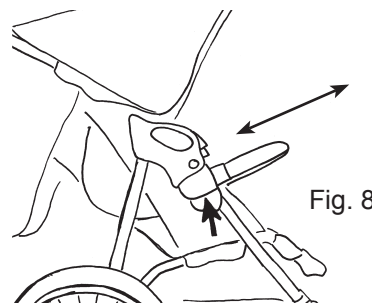

Fig. 8

**! SAFETY !**  
Never leave the MARCO MARATHON TWIN without engaging the brakes.

**TO FIT THE MUDGUARD**

Place in position and secure with the screws provided (Fig. 6).

**TO OPEN AND CLOSE THE SAFETY BELT**

The MARCO MARATHON TWIN has a five-point shoulder harness.

**TO OPEN:** see Fig. 7

**TO CLOSE:** see Fig. 7

**! SAFETY !**  
Don't forget - always buckle up your child!

**! SAFETY !**  
Always keep the handlebar strap round your wrist.

**TO REMOVE AND REFIT THE SAFETY BAR**

**TO REMOVE:** Press the points underneath the safety bar fitting (Fig. 8) upwards and remove the safety bar by pulling it forwards.

**TO FIT:** Push the safety bar into the fitting until you hear it engage. (Fig. 8)

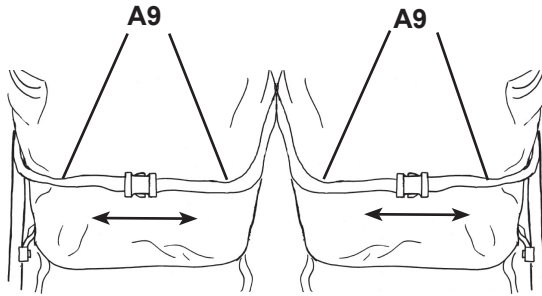

Fig. 9.1

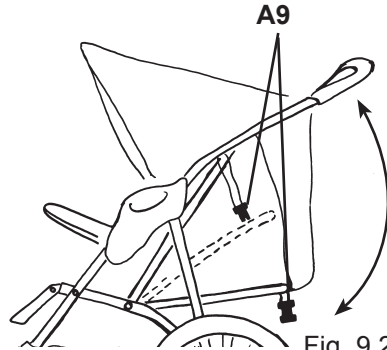

Fig. 9.2

**TO ADJUST THE BACKREST**

The backrest can be adjusted to any position between upright and flat.

**UPRIGHT POSITION:** Push the backrest as far forwards as it will go and fasten the buckle of the backrest straps A9. (Fig. 9.1)

**FLAT POSITION:** Open the buckle of the backrest straps A9 - the backrest will then be flat (Fig.9.2). By lengthening or shortening the straps, any required backrest position can be achieved. (Fig. 9.2)

|  |
|--|
| <b>! MAINTENANCE !</b>   |
| <p>The textiles are removable and handwashable at 30° C.<br/>                 The frame and the spoke wheels should be wiped with a damp cloth and mild soap. Don't use strong detergents, they could damage plastic.<br/>                 Please don't leave your stroller standing on a light coloured surface, particularly PVC or lino, because as with all rubber tyres, it could leave black marks.<br/>                 The tyres can be pumped up with a bicycle pump. Faulty tubes can be repaired with a bicycle puncture repair kit.<br/>                 Regularly lubricate the moving parts with silicon oil or silicon spray.</p> |

|   |
|---|
| <b>! NOTE !</b>   |
| <p>This vehicle is intended for 2 children of at least 6 months, and up to a maximum weight of 15kg.<br/>                 The net basket should not be loaded with more than 3 kg.<br/>                 Spare parts or accessories which are not approved by the manufacturer or dealer may not be used.<br/>                 All parts of the vehicle should be inspected regularly to ensure that they function properly.</p> |

|  |
|--|
| <b>! WARNINGS !</b>  |
| <p><b>WARNING:</b> It may be dangerous to leave your child unattended.<br/> <b>WARNING:</b> Ensure that all the locking devices are engaged before use.<br/> <b>WARNING:</b> Any load attached to the handle affects the stability of the pram/pushchair.<br/> <b>WARNING:</b> Always use the crotch straps in combination with the waist belts.</p> |

**English**



**USER'S INSTRUCTIONS**

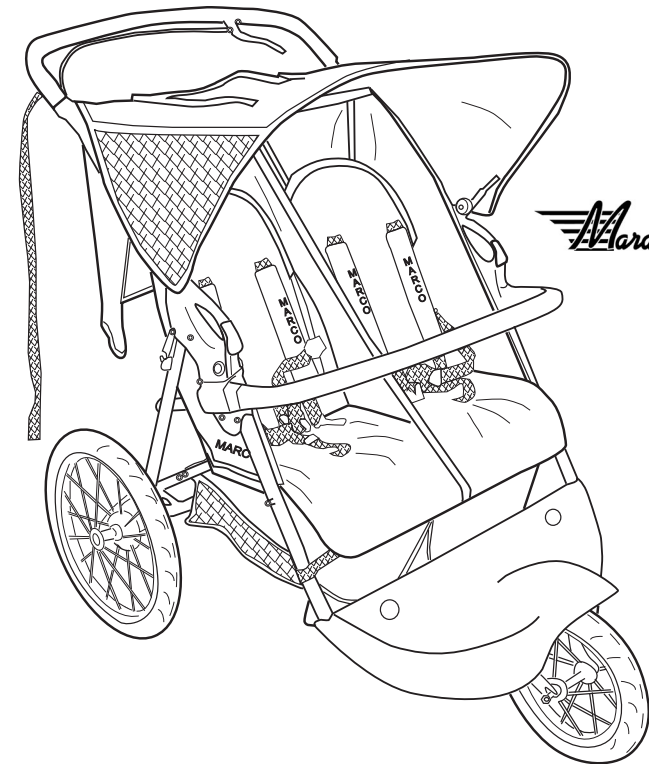

*MARATHON TWIN*

**IMPORTANT:** Read these instructions carefully before use and keep them for future reference. Your children's safety may be affected if you do not follow these instructions.

MARKETING AND DISTRIBUTION  
 MARCO HANDELSGESELLSCHAFT M.B.H.  
 A-5440 GOLLING, AUSTRIA  
[www.marco4bb.com](http://www.marco4bb.com)

© MARCO HANDELSGESELLSCHAFT M.B.H., 2006  
 A-5440 Golling, Austria