

**TO OPEN**

Release the hook A1 (Fig.1.1) and pull up the handlebar. Hold the handlebar firmly with one hand and push down on the safety bumper until the frame locks engage.

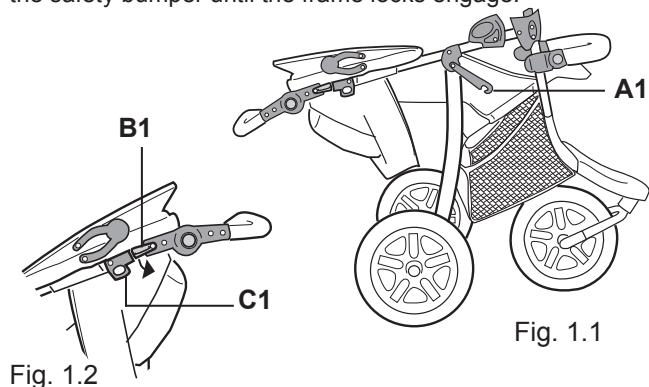

**TO FOLD**

Fold the canopy and adjust the backrest to the flat position. Press the locking lever B1 downwards and pull the levers C1 upwards on both sides (Fig. 1.1, Fig. 1.2). Fold the stroller and close the hook A1. (Fig. 1)

**TO FIT THE FRONT WHEEL**

Push the front wheel with its mounting C2 onto the tubes A2 until the spring buttons B2 engage in the openings of the mounting C2. (Fig. 2)

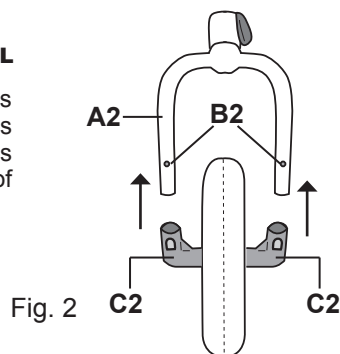

**TO FIX AND TO SWIVEL THE FRONT WHEEL**

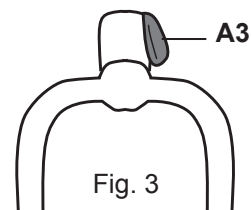

**TO FIX:** Push the lever A3 to the side (Fig. 3).

**TO SWIVEL:** Push the lever A3 to the front.

**REAR WHEELS AND AXLE**

**AXLE:** Push the axle bar A4 onto the rear frame tubes, so that the spring-buttons B4 fit into the openings C4 on the rear axle mounting and engage. (Fig. 4.1)

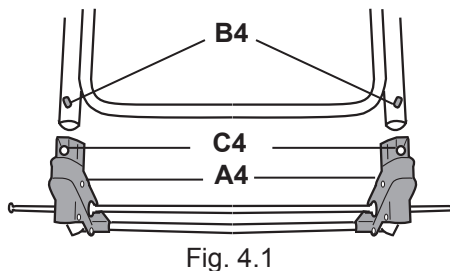

**WHEELS:**

**TO FIT:** Push the wheel onto the axle bar until you distinctly hear it engages. (Fig. 4.2)

**TO REMOVE:** Press the button D4 and remove the wheel (Fig. 4.2).

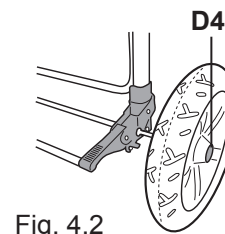

**TO FIX AND TO RELEASE THE BRAKES**

The MARCO Trigon QX is fitted with a „one-touch“ brake.

**TO FIX:** Press down the brake bar A5 with your foot until you feel it engages (Fig. 5).

**TO RELEASE:** Press the brake bar A5 upwards (Fig.5).

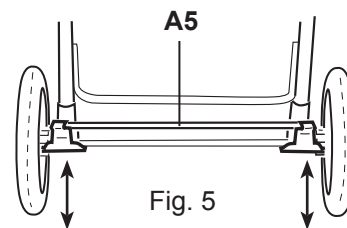

**TO REMOVE AND REFIT THE SAFETY BAR**

**TO REMOVE:** Open the fitting levers A6 on both sides, and remove the bumper (Fig 6).

**TO FIT:** Put the bumper onto the frame and close the fitting levers A6 on both sides. (Fig. 6)

**TO ADJUST:** Press the buttons B6 on both sides of the bumper and adjust it into the desired position. (Fig. 6)

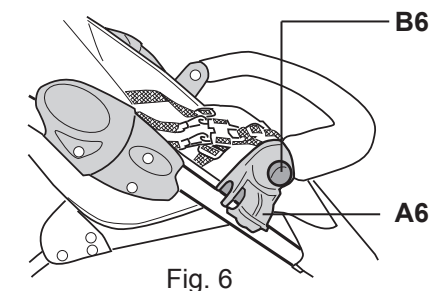

**TO ADJUST THE BACKREST**

Pull up the backrest release A7 and adjust the backrest to the required position. (Fig. 7)

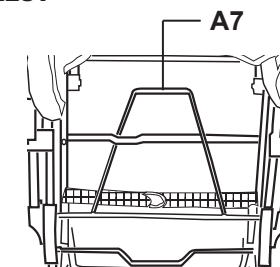

**TO FIT THE CANOPY**

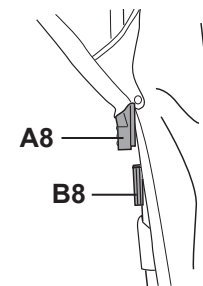

Put the canopy fittings A8 on both sides of the canopy onto the guideways B8 on the frame tubes until you feel them engaged (Fig. 8) and fasten the velcros.

**TO ADJUST THE HANDLEBAR**

Press the buttons A9 on either side of the handlebar and move it to the required position. (Fig. 9)

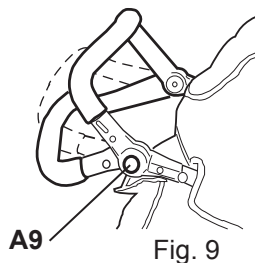

**SAFETY HARNESS**

This stroller has a 5-point harness system. For extra safety D rings are provided for the attachment of a separate safety harness. (Fig. 10.3)

TO OPEN: Press the clips A10 and pull them out of the buckle B10. (Fig. 10.1, 10.2)

TO CLOSE: Push the clips A10 on the right and left shoulder harness into the buckle B10. (Fig. 10.2)

TO ADJUST: Move the slide adjusters C10 upwards or downwards. (Fig. 10.3)

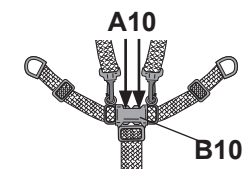

Fig. 10.1

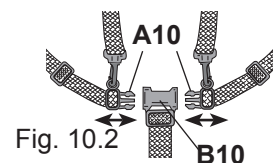

Fig. 10.2

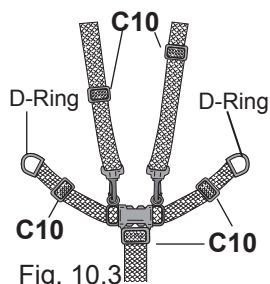

Fig. 10.3

**MAINTENANCE**

The textiles are removable and handwashable at 30° C.

The frame and the wheels should be wiped with a damp cloth and mild soap. Don't use strong detergents, they could damage plastic. Regularly lubricate the moving parts with silicon oil or silicon spray.

**NOTE**

This vehicle is intended for children up to a max. weight of 15 kg. The net basket should not be loaded with more than 3 kg.

The vehicle is designed to be used by one child only.

Spare parts or accessories which are not approved by the manufacturer or dealer may not be used.

Periodically check all parts for wear or damage. Do not use stroller if any component is broken or damaged.

Please do not make any changes to the stroller that could affect the safety.

**WARNINGS**

- ▲ It may be dangerous to leave your child unattended.
- ▲ Ensure that all the locking devices are engaged before use.
- ▲ Always use the safety harness.
- ▲ Any load attached to the handle affects the stability of the pram/pushchair.

**USER'S INSTRUCTIONS**

We congratulate you on your purchase of your Jogger with front swivel wheel. This pushchair offers optimal performance + value and is very easy to use.

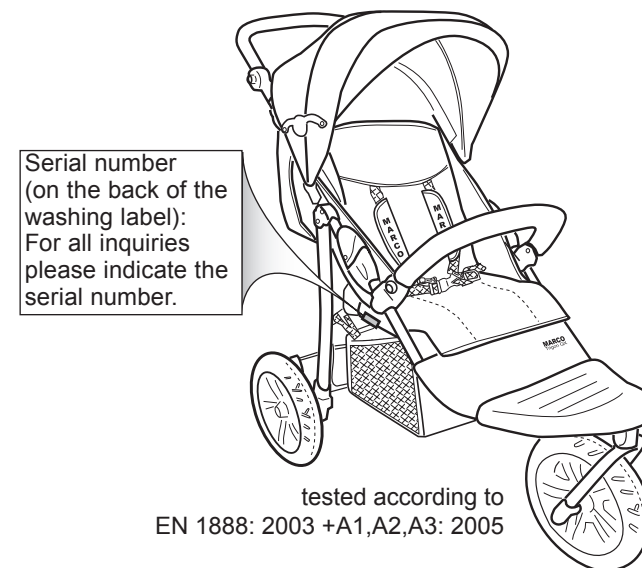

**IMPORTANT:** Read these instructions carefully before use and keep them for future reference. Your child's safety may be affected if you do not follow these instructions.

MARKETING AND DISTRIBUTION  
MARCO HANDELSGESELLSCHAFT M.B.H.  
A-5440 GOLLING, AUSTRIA  
[www.marco4bb.com](http://www.marco4bb.com)

© MARCO HANDELSGESELLSCHAFT M.B.H., 2008  
A-5440-Golling, Austria